



## Servo reducers 2S-R90

AKIM gear technology – Swiss Made.

## Servo reducers 2S-R90.

A high dynamic and very precise modularly built cycloid gear. The compact and coaxial design allows to achieve greatest ratios on minimal space. The reducers are assembled with a minimum of moving parts, have lifetime lubrication and therefore completely maintenance free.

### General informations.

- Minimum backlash <1 min (<0.02°)
- Can be adjusted to “backlash-free”
- Minimum mass moment of inertia
- High torsional rigidity
- Maximum overload safety
- Optimized efficiency >90%
- Compact, coaxial form
- Special designs and special executions are possible (on request)
- Small to largest ratios with minimal space requirement
- Drive speeds well up to 5000 min<sup>-1</sup>
- Ratios from 10 to 100 : 1 achievable in single stage. Multi stage reducers are available on request
- Easy motor mounting (normal shaft end, normal concentricity)
- Installation: horizontal or vertical
- All the moving parts rotate on roller bearings
- Minimum of moving parts
- All-round sealing
- Lifetime lubrication
- No oil fittings
- Maintenance free

### Available in 6 different types.

- **2S-R90/00** – for 80 Nm
- **2S-R90/0** – for 150 Nm
- **2S-R90/1** – for 400 Nm
- **2S-R90/2** – for 1000 Nm
- **2S-R90/3** – for 2000 Nm
- **2S-R90/4** – for 4000 Nm

Please check our diagrams and tables or contact us. We will be happy to advise you.

**Torque / Mass moment of inertia / Torsional rigidity.**

Type	2S-R90/00	2S-R90/0	2S-R90/1	2S-R90/2	2S-R90/3	2S-R90/4
Nominal torque (S1) $T_2$	Nm	80	150	400	1000	4000
Max. (S3 1% ED) $T_2$ max	Nm	120	220	600	1500	6000
Mass moment of inertia J	kgcm <sup>2</sup>	0.007	0.06	0.19	0.58	2.25
Torsional rigidity $T_2$	Nm/min	11	22	30	59	118
Weight C2	kg	2.5	8	18	31	47
Weight C9	kg	3	9	19	33	102

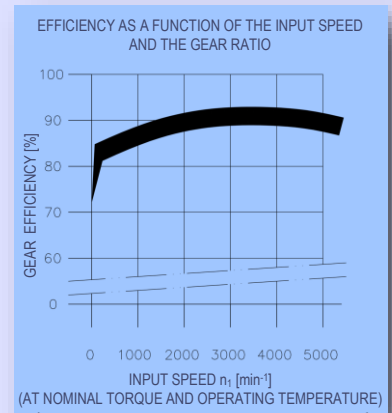
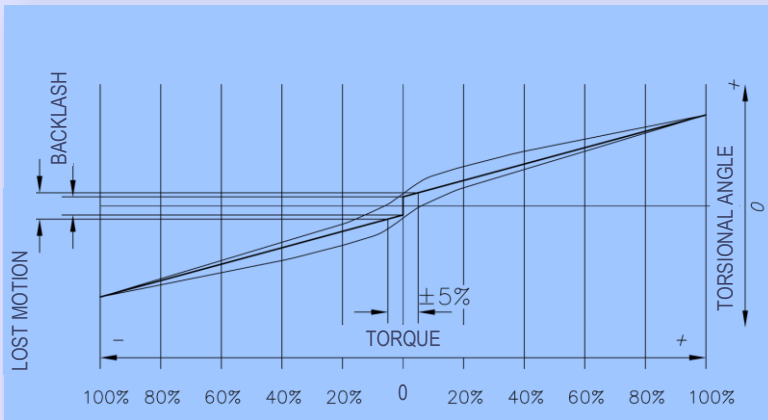

**Ratios.**

Type	Possible gear ratios																												
	13	14	16	17	19	21	24	26	29	30	32	36	38	45	48	55	60	62	65	66	70	73	75	78	80	90	97	100	
2S-R90/00		o			o		o		o			o			o		o							o					
2S-R90/0	o		o		o		o			o	o		o					o							o*				o*
2S-R90/1				o		o		o				o		o		o				o		o						o*	
2S-R90/2		o				o		o				o		o		o		o				o				o	o		
2S-R90/3		o				o		o				o		o		o		o				o				o	o		o
2S-R90/4			o			o		o				o		o		o		o				o				o	o		o

\* Used only with reduced torque

Mounting types.

C2

C9

C7

C8

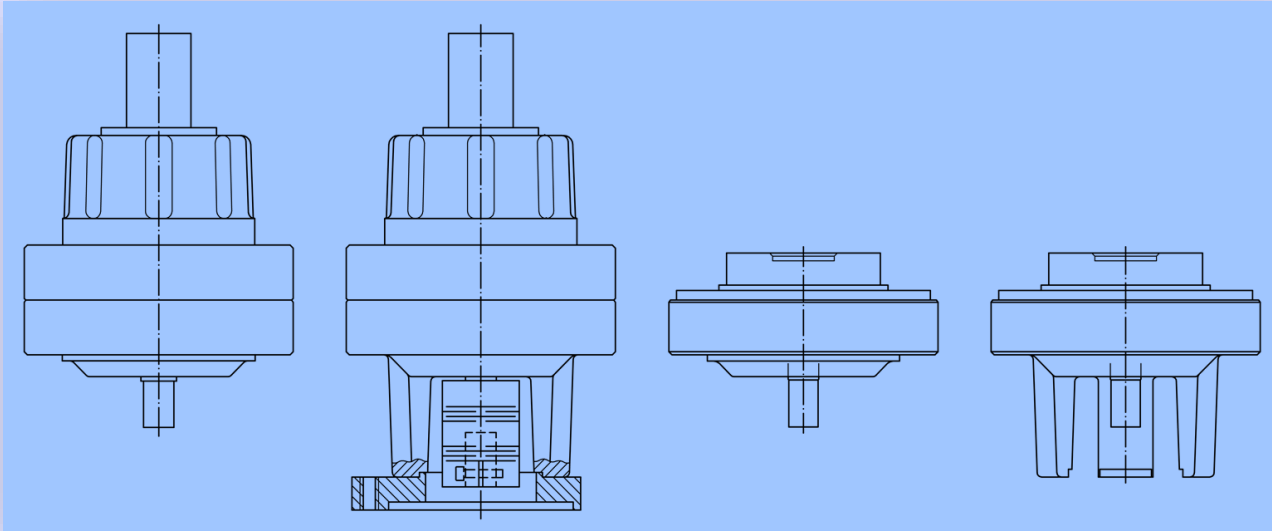

Drawings.

Type C2

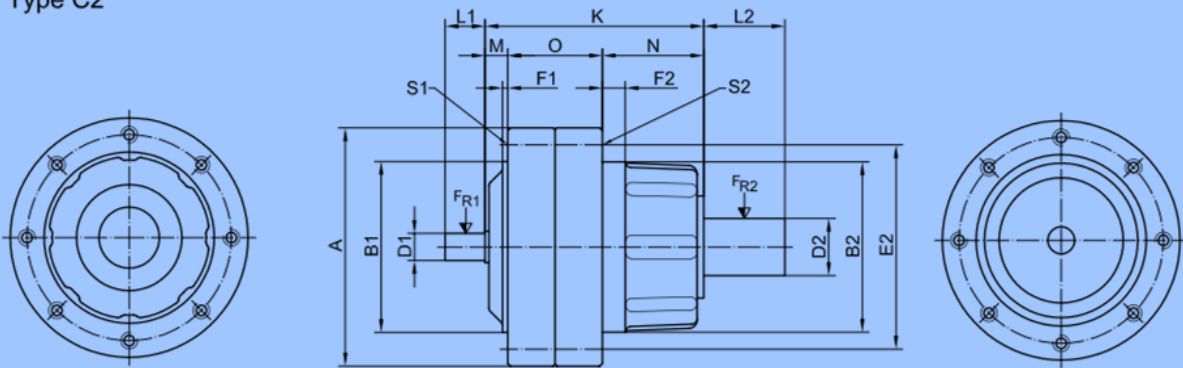

Type C9

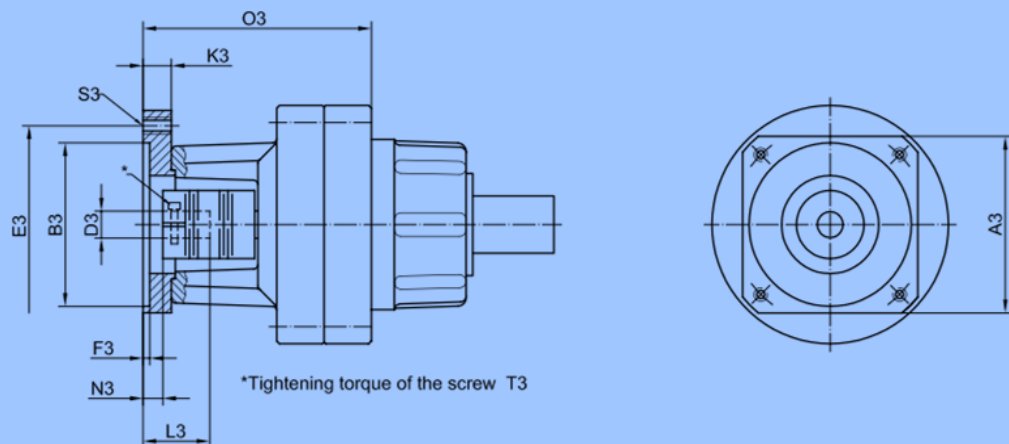

Type C7 and C8 on request

**Dimensions.**

		Type	2S-R90/00	2S-R90/0	2S-R90/1	2S-R90/2	2S-R90/3	2S-R90/4
Designs		Dimensions						
C2, C9	A	90	135	175	210	245	310	
	K	88	132	162	197	224	269	
	O	43	60	71	85	93	112	
	M	7	15	16	16	16	17	
	N	38	57	75	96	115	140	
Input C2	B1	Ø65-h6	Ø95-h6	Ø125-h6	Ø150-h6	Ø175-h6	Ø210-h6	
	E1	Ø75	Ø112	Ø150	Ø180	Ø210	Ø260	
	F1	5	4	4	5	5	7	
	D1	Ø11-k6	Ø14-k6	Ø19-k6	Ø24-k6	Ø28-k6	Ø32-k6	
	L1	18	22	30	40	50	60	
	S1	6 x M5x8	8 x M6x12	12 x M6x12	6 x M8x16	6 x M10x20	6 x M12x25	
Output C2, C9	B2	Ø65-h6	Ø95-h6	Ø125-h6	Ø150-h6	Ø175-h6	Ø210-h6	
	E2	Ø75	Ø112	Ø150	Ø180	Ø210	Ø260	
	F2	10	12	17	20	22	25	
	D2	Ø19-k6	Ø32-k6	Ø42-k6	Ø55-k6	Ø65-k6	Ø85-k6	
	L2	30	45	60	80	105	130	
	S2	6 x M5x10	8 x M6x15	12 x M8x20	12 x M10x20	12 x M12x25	12 x M14x30	
Motor installation C9	F3	3	4	5	5	6	7	
	N3	10	17	18	24	34	29	
	K3	13	15	23	23	25	30	
	O3	100	140	172	205	243	277	
	T3	3.8 Nm	8 Nm	13 Nm	32 Nm	32 Nm	32 / 64 Nm	

**Motor installation.**

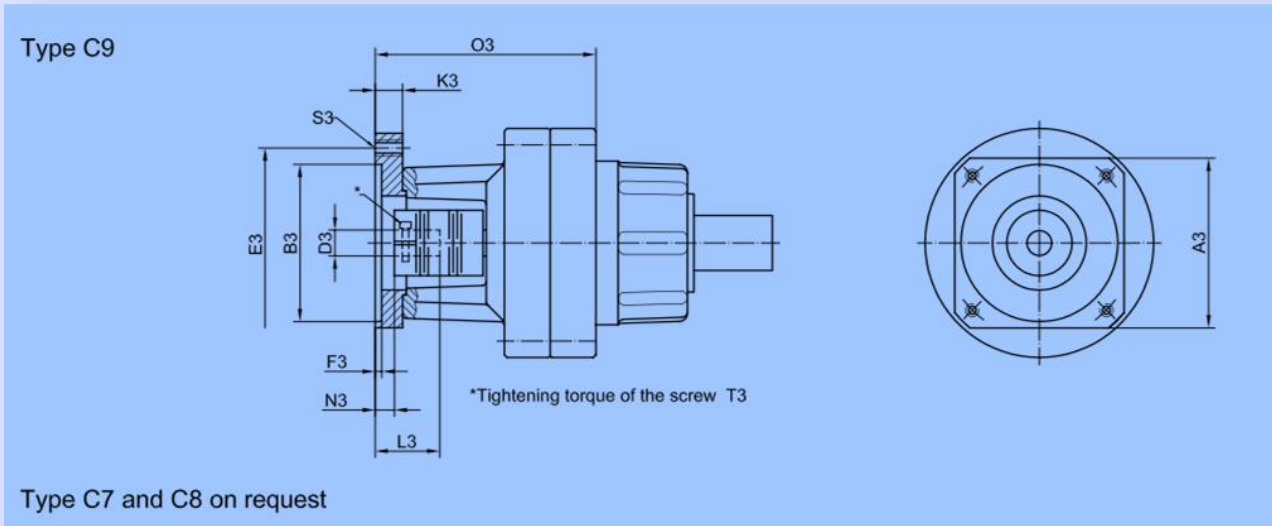

**Motor flange dimensions.**

Dimensions						Type						
A3	B3	E3	D3	L3	S3	2S-R90/00	2S-R90/0	2S-R90/1	2S-R90/2	2S-R90/3	2S-R90/4	
Ø80	50	65	11	23	4 x Ø5.5	o						
70x70	60	75	11	23	4 x M6	o						
90x90	80	100	14	30	4 x M6	o	o					
100x100	95	115	14	30	4 x M8	o	o					
Ø90	60	75	11	23	4 x M6		o					
115x115	95	130	19	40	4 x M8		o					
115x115	110	130	19	40	4 x M8		o					
Ø120	80	100	14	30	4 x M6			o				
Ø140	95	115	14	30	4 x M8			o				
120x120	95	130	19	40	4 x M8			o				
120x120	110	130	24	50	4 x M8			o				
140x140	110	165	24	50	4 x M10			o	o			
140x140	130	165	24	50	4 x M10			o	o			
Ø140	95	115	19	40	4 x M8				o			
Ø160	110	130	24	50	4 x M8				o			
160x160	130	165	24	50	4 x M10					o		
190x190	130	215	32	58	4 x M12					o		
190x190	180	215	38	80	4 x M12					o		
200x200	180	215	38	80	4 x M12						o	
260x260	250	300	48	82	4 x M16						o	

Other dimensions on request

**Radial load input shaft.**

Type		2S-R90/00	2S-R90/0	2S-R90/1	2S-R90/2	2S-R90/3	2S-R90/4
Drive speed		Max. permissible radial load $F_{r1}$ [N] related to the centre of the input shaft					
N <sub>1</sub>	200	460	2100	2200	3200	5400	6600
	500	320	1400	1500	2400	4400	5500
	1000	220	1050	1150	1750	3600	4500
	2000	125	750	800	1075	2900	3850
	3000	75	550	650	825	2450	3100
	4000	40	425	500	625	2200	2750
	5000	20	350	450	550	1975	2450

**Radial / Axial load output shaft.**

Type		2S-R90/00	2S-R90/0	2S-R90/1	2S-R90/2	2S-R90/3	2S-R90/4
Drive speed		Max. permissible radial load $F_{r2}$ [N] related to the centre of the output shaft					
N <sub>2</sub>	10	4000	8450	14500	20000	21200	31100
	15	3500	7300	12500	18000	18500	27200
	25	2900	6200	10500	15000	15800	22500
	40	2525	5250	9000	13000	13500	19500
	65	2150	4500	7600	11000	11500	16700
	100	1850	4000	6800	9200	10000	14200
	160	1600	3400	5700	8000	8500	12300
	250	1325	3000	5000	6800	7300	10500
Drive speed		Max. permissible axial load $F_{a2}$ [N] related to max. permissible radial load $F_{r2}$					
N <sub>2</sub>	10	2625	5900	9250	14400	15000	21400
	15	2250	4900	7700	12700	12600	18000
	25	1800	4000	6300	10100	10500	14500
	40	1550	3250	5100	8500	8200	12200
	65	1225	2600	4400	7000	6800	10000
	100	1025	2200	3800	5200	5800	8100
	160	825	1600	3000	4300	4200	6500
	250	625	1300	2500	3200	3500	5400